

# ELOTEST HST 3

## Heavy Plate Hard Spot Tester



The ELOTEST HST-3 testing trolley is used for the detection of partial hardening spots on heavy plates. The ELOTEST HST-3 is designed for manual testing of large-areas on semi-finished products using the EDDY+ method. The test signals of the integrated ELOTEST PL600 R eddy current tester are directly displayed as a C-Scan on the fully robust mobile PC (Panasonic Toughbook) included in the scope of delivery. The recorded data can be immediately evaluated and documented here. The system status is additionally visualized to the operator via clearly visible signal lamps. This makes the ELOTEST HST-3 mobile inspection system predestined for use in harsh steel mill environments. Two powerful and exchangeable lithium-ion rechargeable batteries make the test system suitable for up to 20 hours of use independent of mains power.

- ▶ ELOTEST PL600 R Eddy current testing instrument
- ▶ Two hardware testing channels in the ELOTEST PL600
- ▶ Scanalyzer 7 evaluation software
- ▶ Panasonic Semi Ruggedized 14"-TOUGHBOOK 54 HD incl. a second battery pack
- ▶ Two external multiplexers to connected 4 probes each
- ▶ Eight probes, each with 8 integrated sensors
- ▶ Robust and wear-resistant zirconium oxide industrial ceramic soles on the probe
- ▶ 100% testing area coverage of 640 mm
- ▶ Test speed up to 1m/s (corresponds to normal step speed)
- ▶ Two mutually independent, replaceable high-performance lithium-ion battery packs
- ▶ Battery packs can be switched during operation

## Dimensions and design of the system:

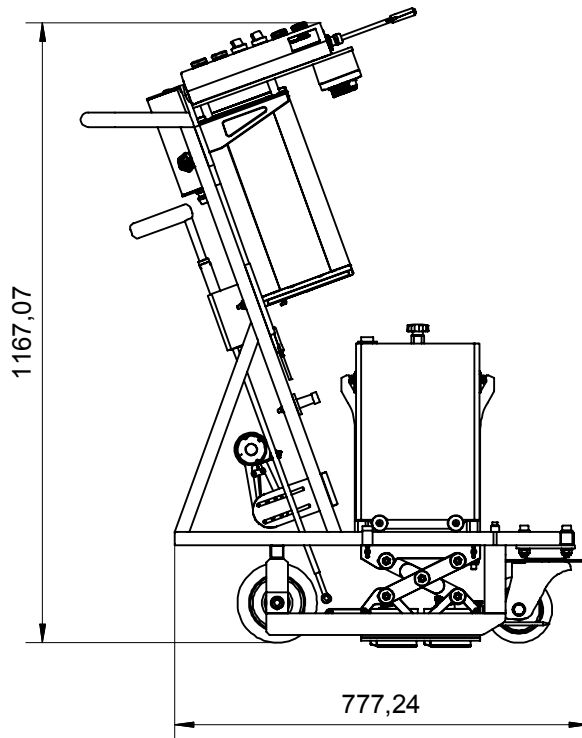
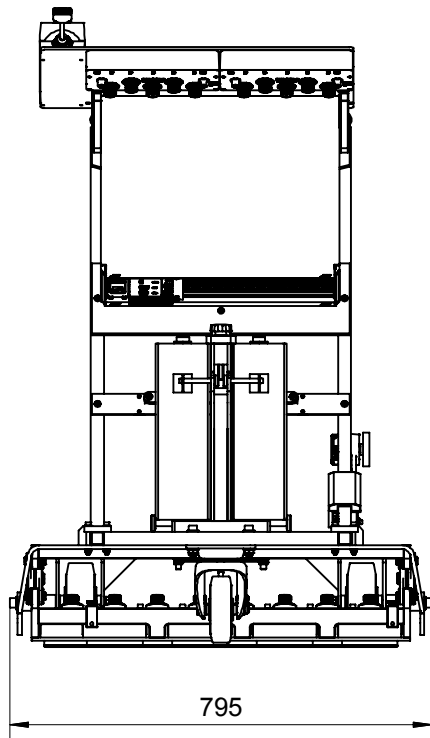

### Technical data of the battery system:

- ▶ Length x width x height of one battery pack:  
232 x 103 x 333 mm
- ▶ Weight of one battery pack: 9,6 kg
- ▶ Technology: Lithium-Ion
- ▶ Nominal voltage: 50,4 Volt
- ▶ Capacity: 28,5 Ah / 1350 Wh
- ▶ Working range charging: 0°C to +45°C
- ▶ Unloading work range: -20°C to +60°C
- ▶ Charging time from deep discharge cut-off threshold to 100% approx. 4 hours
- ▶ 10 hours testing time per battery pack (applies to the trolley and the mobile PC)

All components are fully assembled, matched and tested.  
Supplied with 100% charged batteries and ready for use.

### Scope of delivery of the HST-3 testing system (article no.: A0M1093004001011):

- ▶ HST-3 testing trolley frame with probe carrier
- ▶ Panasonic Semi Ruggedized 14"-TOUGHBOOK 54 HD incl. a second battery pack
- ▶ Scanalyzer 7 software
- ▶ Integrated ELOTEST PL600 R Eddy Current testing instrument
- ▶ 8 probes with all cables and external multiplexers
- ▶ 2 Lithium-Ion battery packs incl. 1 charger
- ▶ Ready to use total weight incl. PC and 2 battery packs: 101 kg